

FUSIONSEEKER DS-100D10

ULTRA HIGH ACCURACY SENSORY SOLAR TRACKER CONTROLLER



INSTRUCTION MANUAL

Revision 3

TABLE OF CONTENTS

1. INTRODUCTION	3
2. TECHNICAL SPECIFICATIONS.....	4
3. INSTALLATION INSTRUCTIONS	5
3.1 <i>Setting the input voltage range</i>	6
3.2 <i>Setting the tracking accuracy</i>	7
3.3 <i>Mounting FUSIONSEEKER on the solar "receiver"</i>	10
3.4 <i>Connecting FUSIONSEEKER to supply voltage/s and motors</i>	12
3.5 <i>The use of limit switches</i>	16
3.6 <i>Grounding</i>	17
4. RECOMMENDATIONS FOR SOLAR TRACKER STRUCTURE	17
5. WARRANTY	18

1. INTRODUCTION

FUSIONSEEKER DS-100D10 is a **universal ultra high accuracy sensory solar tracker controller** designed to be used with **all** dual-axis solar trackers (high concentration ratio solar concentrators included!!!) that use permanent magnet DC motors for moving. Its superiorities are **ultra high tracking accuracy, great electrical capabilities, ultra high reliability, long expected life time and also watertight "3in1" pure aluminium housing that serves as a heat sink for POWER MOS-FET transistors, as a "shadow maker" for sensors and as an all weather resistant protection for electronics.** Installation is also very simple - because all components are packed in **one** "3in1" housing. You just fix it on to the solar "receiver", connect to supply voltage and motors and that's it. And don't forget it's maintenance free - install and forget!

The heart of FUSIONSEEKER DS-100D10 is its **100% solid state** (no moving parts inside, no potentiometers, no relays!!!) and software free (all features are implemented with pure hardware - no reset buttons, no Windows[®] blue screens!!!) electronics that for functioning needs so little power that energy consumption (about 0,002 kWh per day) can simply be ignored. DS-100D10 is working on a principle of equalized output signals of its four light sensors. Two of them are used for azimuth tracking and the other two are used for elevation tracking. The azimuth and elevation tracking principles are identical, so it's enough to describe just, for example, azimuth tracking. When output signals from two azimuth tracking sensors are different (solar "receiver" is not faced precisely to the sun - "3in1" housing is shading one light sensor) electronics, with the help of POWER MOS-FET transistors, turns on the azimuth motor and keeps it running. Immediately after output signals from sensors equalize (solar "receiver" is again faced precisely to the sun) the azimuth motor is turned off and with the help of **electronic brake** instantly stopped. This electronic brake is in function always but it becomes absolutely necessary in case you set DS-100D10's accuracy to ultra high level (without brake system oscillates!). This sequence is repeating throughout all day till sunfall when tracker (motor) stops facing to the west. Elevation tracking works in the same way (independently!) only that elevation sensors and elevation motor are in function.

Next morning when first sun rays appear DS-100D10 with its additional (fifth) **bottom sensor** notices that and turns on the azimuth motor to move the tracker to the east. After some 5 minutes (it depends on the speed of tracker's rotation) tracker is facing to the east and sequence described above starts to repeat again.

In case when clouds cover the sun DS-100D10 can stop tracking or it can turn solar tracker towards the brightest cloud - that depends on what tracking accuracy you choose (set). And immediately after clouds disappear it will in every case turn the tracker toward the sun. In short, FUSIONSEEKER DS-100D10 is a solar tracker controller that will always satisfy all your dual-axis sun tracking needs.

2. TECHNICAL SPECIFICATIONS

☀ FUSIONSEEKER DS-100D10 ☀	
Type:	"dual-axis"
Supply voltage (DC):	<p>AZIMUTH tracking: Uin = from 10V to 100V DC covered with three selectable input voltage ranges: Voltage range A: Uin = from 10V to 25V Voltage range B: Uin = from 20V to 50V Voltage range C: Uin = from 40V to 100V Factory defaults: voltage range B</p> <p>ELEVATION tracking: Uin = from 10V to 100V DC covered with three selectable input voltage ranges: Voltage range A: Uin = from 10V to 25V Voltage range B: Uin = from 20V to 50V Voltage range C: Uin = from 40V to 100V Factory defaults: voltage range B</p>
Accepted (applicable) supply voltage sources:	Any external power supply or battery or solar cells (for details see Section 3.4)
Output current (max. motor current):	<p>AZIMUTH tracking: Iout,cont. = 10A (continuous load!!!) Iout,10s = 15A (up to 10 seconds) Iout,max = 45A (short duration - for motor startup)</p> <p>ELEVATION tracking: Iout,cont. = 10A (continuous load!!!) Iout,10s = 15A (up to 10 seconds) Iout,max = 45A (short duration - for motor startup)</p>
Output voltage (motor voltage):	<p>AZIMUTH tracking: Uout = Uin - 0,9V at Iout = 5A Uout = Uin - 1,8V at Iout = 10A</p> <p>ELEVATION tracking: Uout = Uin - 0,9V at Iout = 5A Uout = Uin - 1,8V at Iout = 10A</p>
Electronics self consumption:	<p>AZIMUTH tracking: at Uin = 12V just 0,8mA at Uin = 24V only 1,3mA at Uin = 48V only 1,3mA</p> <p>ELEVATION tracking: at Uin = 12V just 0,8mA at Uin = 24V only 1,3mA at Uin = 48V only 1,3mA</p> <p>(and intelligently built electronics consume always the same without regard to DC motor being in operation or not!)</p>
Tracking accuracy:	up to ±0,01 degree at 1000W/m ² (it is settable) Factory defaults: ± 0,1 degree (at 1000W/m ²)
Electronic motor brake:	YES
Operating temperature range:	from -25°C to +70°C
Housing:	Material: pure aluminium (Al) Colour: silver (UV and high temperature resistant) IP class: IP 67 (housing is watertight - it works even underwater)
Dimensions:	width: 100mm, height: 140mm, length: 160mm
Weight:	0,95kg
Maintenance:	It's maintenance free
Expected life time:	15 years +

3. INSTALLATION INSTRUCTIONS

WARNING! Please read those instructions completely - before starting with installation!

WARNING! Installation can be performed by qualified Electrician only!

Figure 1 is showing what comes with FUSIONSEEKER DS-100D10:

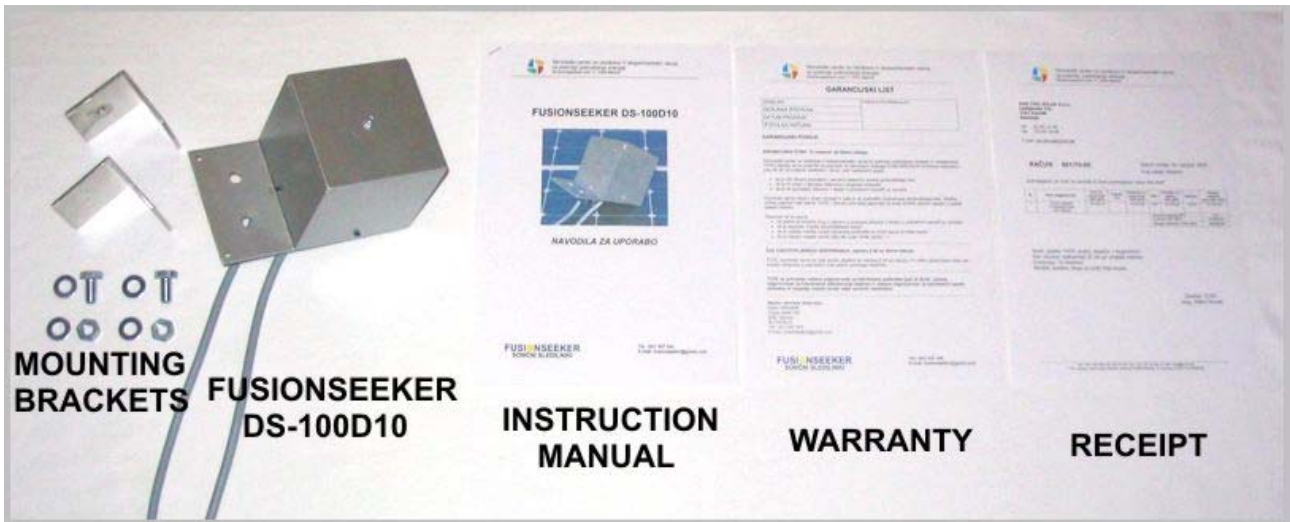

Figure 1: FUSIONSEEKER DS-100D10 package

The following sections will guide you how to set parameters of DS-100D10, how to mount it onto the solar "receiver", how to connect supply voltage/s and motors and where you have to be careful.

Read all sections step by step and installation will be easy.

Before you start look at **Figure 2** where all important components of FUSIONSEEKER DS-100S10 are marked - for easier understanding.

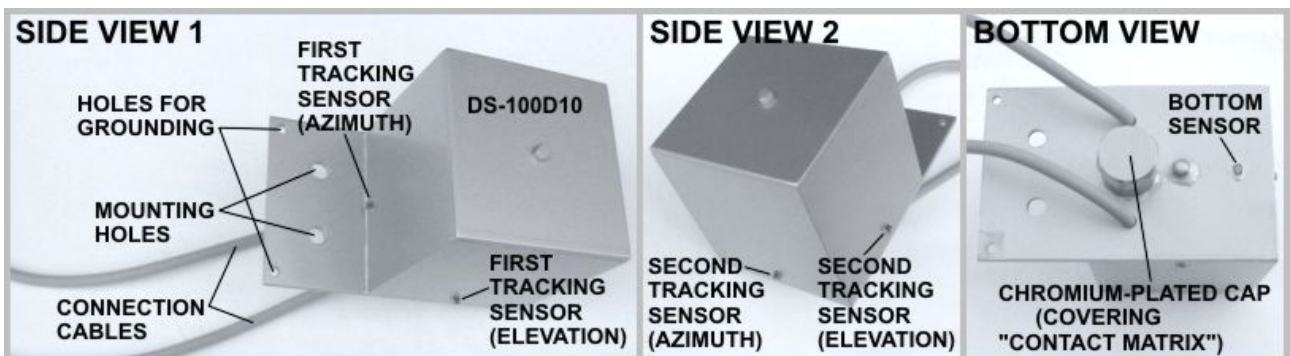

Figure 2: Components of FUSIONSEEKER DS-100D10

3.1 Setting the input voltage range

WARNING! You can change the input voltage range only when FUSIONSEEKER DS-100D10 is not connected to supply voltage!

Inside FUSIONSEEKER DS-100D10 the electronics for azimuth tracking and elevation tracking are completely independent. The part for azimuth tracking can operate at one supply voltage **which is always equal to the rated voltage of your azimuth actuator motor** and the part for elevation tracking can operate at the other supply voltage **which is always equal to the rated voltage of your elevation actuator motor**.

FUSIONSEEKER DS-100D10 can operate at supply voltages from 10V DC to 100V DC which are covered with three voltage ranges **that are settable independently for azimuth tracking and elevation tracking:**

Voltage range A: U_{in} = from 10V to 25V

Voltage range B: U_{in} = from 20V to 50V

Voltage range C: U_{in} = from 40V to 100V

For example, if you want to connect FUSIONSEEKER DS-100D10 for azimuth and elevation tracking to 12V accumulator, because your tracker uses two 12V permanent magnet DC motors, set both azimuth and elevation part of it to voltage range **A**. If input voltage for azimuth and elevation tracking will be between 20V DC and 50V DC you set nothing because voltage range **B** is factory default setting for azimuth and elevation tracking. The advantage of using the same voltage range (the same input voltage) for azimuth and elevation tracking is that you need only one power supply. In case supply voltage for azimuth tracking is for example 15V (voltage range **A**) and supply voltage for elevation tracking for example 72V (voltage range **C**) you need two power supplies. Sometimes there is a question what voltage range to choose if input voltage for azimuth and/or elevation tracking will be 45V. The answer is **B** or **C** but in these cases it is recommended to always choose higher voltage range (voltage range **C** in this case).

If you have to change the voltage range, turn DS-100D10 so that you can see it from exactly the same perspective as shown on **Figure 3** (step 1). Then unscrew the chromium-plated cap. Inside there is a "contact matrix" with 24 gold-plated contact holes. You set the desired voltage range independently for azimuth and/or elevation tracking with the help of jumpers as described on the **Figure 3** (step 2).

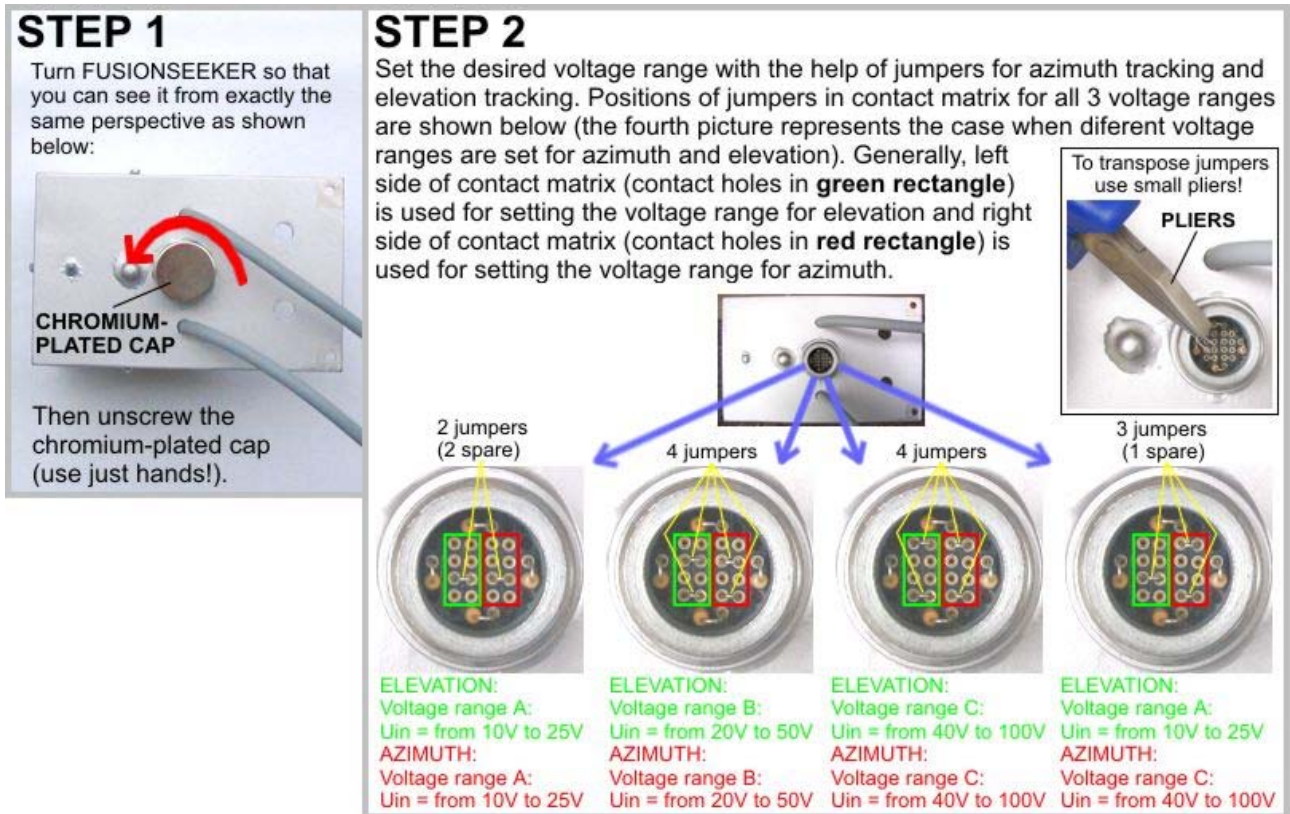

Figure 3: Setting the input voltage range

When you finish place **two seals** that assure watertightness back into the chromium-plated cap and then screw the cap down (use just hands!).

3.2 Setting the tracking accuracy

FUSIONSEEKER DS-100D10 is a dual-axis solar tracker controller which provides you the possibility to track the sun with ultra high tracking accuracy of up to $\pm 0,01$ degree. Tracking accuracy is also settable but first we are going to explain some facts.

Sun has a radius of 700.000 km and the distance between earth and sun is on average 149.000.000km. It is not hard to calculate that viewing angle at which we see sun from earth is $\pm 0,27$ degree (absolute value: 0,54 degree) (look at **Figure 4**).

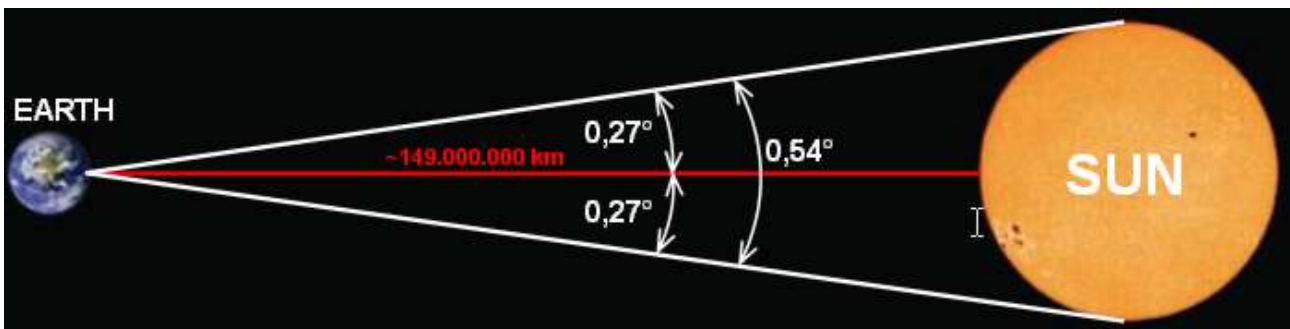

Figure 4: Viewing angle at which we see the sun

When you know the facts you ask yourself: Does tracking accuracy of better than $\pm 0,27$ degree make any sense? The answer is YES and NO – it depends on the type of solar "receiver". In case of

using flat solar "receivers" like are solar cells or water heating solar collectors there is certainly no need for high tracking accuracy - in practice you lose just small amount of energy even with bad accuracy of ± 5 degree - but high accuracy will certainly give best results. Situation changes when solar concentrators, such is parabolic dish solar concentrator, are used. In this case tracking accuracy of at least $\pm 0,27$ degree is absolutely necessary because otherwise concentrator can go out of focus and the consequence is drastically decreased output power.

In the beginning of this section it was said tracking accuracy is settable. You change it in the following way:

Turn DS-100D10 so that you can see it from exactly the same perspective as shown on **Figure 6** (step 1). Then unscrew the chromium-plated cap. Inside there is a "contact matrix" with 24 gold-plated contact holes. On the left, right, top and bottom side of "contact matrix" there are **four equal resistors marked as R14a, R15a, R14e and R15e**. You change tracking accuracy by changing those four resistors with four of different resistance but same size (1/4W).

WARNING! You can change resistors R14a, R15a, R14e and R15e only when FUSIONSEEKER DS-100D10 is not connected to supply voltage!

Before you start setting desired tracking accuracy look at the **Figure 5**. The graph is showing how tracking accuracy depends on different resistance of resistors R14a, R15a, R14e and R15e at certain solar irradiance.

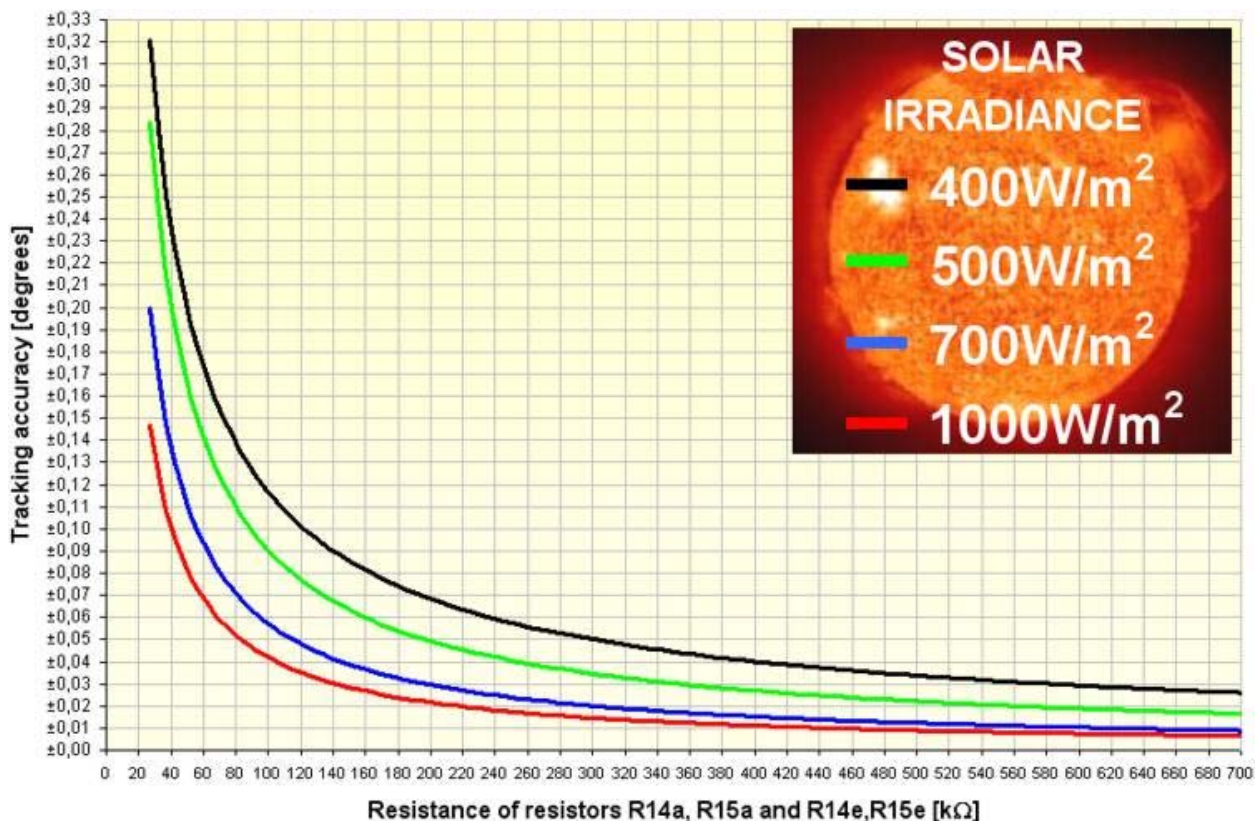

Figure 5: How tracking accuracy depends on different resistance of resistors R14a, R15a, R14e and R15e at certain solar irradiance

With the help of **Figure 5** it is easy to select resistance of resistors R14a, R15a, R14e and R15e for desired tracking accuracy. If you want ultra high tracking accuracy resistance should be higher than 700 kΩ or you can simply "use" **no resistors** (infinite resistance). **Figure 5** is also showing that tracking accuracy decreases if solar irradiance decreases. This characteristic of DS-100D10 makes

sense when clouds cover the sun because tracking stops if "there is nothing to track". And higher accuracy also means that clouds have to be darker to stop the tracking.

Knowing the facts you now ask yourself how to choose the resistance of R14a, R15a, R14e and R15e. The answer is dependant on the type of your solar "receiver":

a) "Flat" solar "receivers":

If you have flat solar "receiver" such are solar cells or water heating solar collectors it is recommended to simply do nothing – use factory defaults $R14a=R15a=R14e=R15e=68k\Omega$. At this resistance tracking accuracy is app. $\pm 0,1$ degree at $1000W/m^2$. Maybe you can increase accuracy ($R14a=R15a=R14e=R15e$ more than $68k\Omega$) in case of solar cells and slightly decrease it ($R14a=R15a=R14e=R15e$ less than $68k\Omega$) in case of water heating solar collectors – experienced users only.

b) Solar concentrators:

When you deal with solar concentrators such are parabolic dish solar concentrators you can also use factory defaults $R14a=R15a=R14e=R15e=68k\Omega$ if tracking accuracy of $\pm 0,1$ degree at $1000W/m^2$ is enough. If not DS-100D10 allows you to increase accuracy ($R14a=R15a=R14e=R15e$ more than $68k\Omega$) up to ultra high levels (up to $\pm 0,01$ degree) that will satisfy even the most advanced tracking systems.

If you decide **not to change** factory default tracking accuracy you just place **two seals** that assure watertightness back into the chromium-plated cap and screw the cap down (use just hands!) – procedure is finished for you!

If you decide to change tracking accuracy and you have already bought four new resistors (price is negligible) change resistors as it's step by step described on the **Figure 6** below.

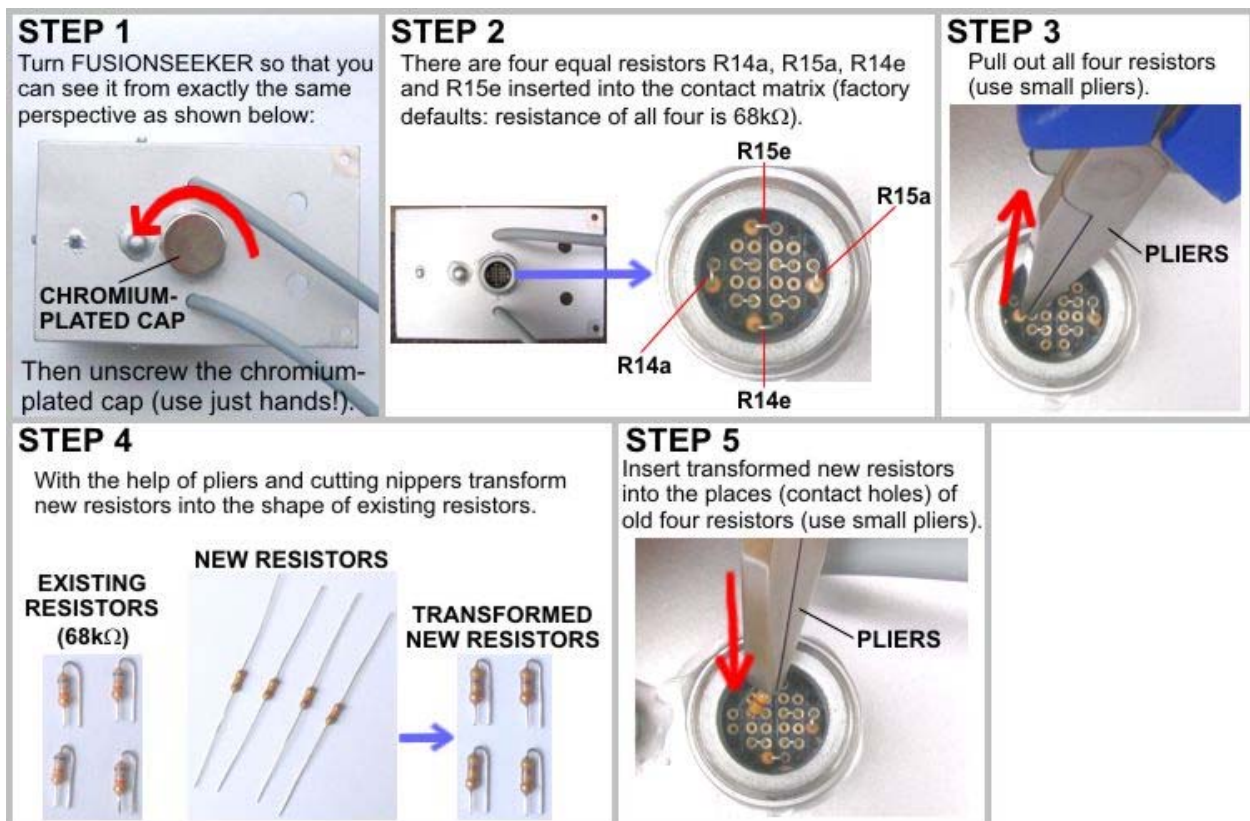

Figure 6: Changing the tracking accuracy (changing R14a, R15a, R14e and R15e)

When you finish place **two seals** that assure watertightness back into the chromium-plated cap and then screw the cap down (use just hands!).

You noticed that changing accuracy with the help of ordinary resistors is somehow unusual. You are right, usually things like that adjust with potentiometers. But potentiometers are not reliable enough because its resistance can change in a few years (oxidation) and parameters of certain device also. For the ultra reliable FUSIONSEEKER that is intolerable. But in the other hand ordinary resistors have very time stable resistance. That's why we invented this unique setting of accuracy. This "contact matrix" has simultaneously another advantage. If you screw up something you can always insert old resistors and return old tracking accuracy what is in case of potentiometers practically impossible.

3.3 Mounting FUSIONSEEKER on the solar "receiver"

Dual-axis tracking systems always consist of tracking the sun by azimuth and tracking the sun by elevation (look at the **Figure 7**):

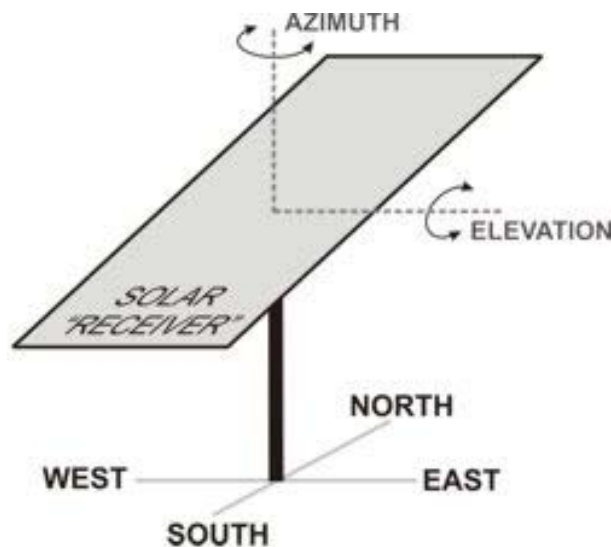

Figure 7: Dual-axis tracking (shown for northern hemisphere)

Essential for tracking is the location on the solar "receiver" where DS-100D10 shall be mounted on. That location depends on global position of the tracker (solar "receiver") as follows:

a) If your tracker (solar "receiver") is positioned somewhere in the northern hemisphere of the earth mount DS-100D10 on the north-east corner of your solar "receiver" as it's shown on Figure 8:

STEP 1
For mounting DS-100D10 on the solar "receiver" (in addition to nuts screws, washers and mounting brackets that are enclosed) you also need:

- additional screw with nut (min. $\phi 6\text{mm}$)
- spanners
- drilling machine
- drill bit

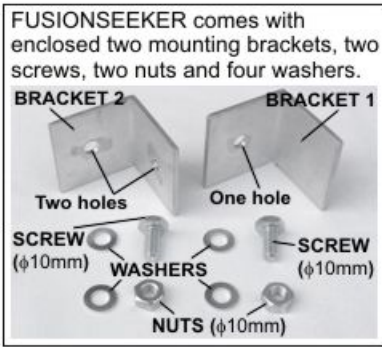

STEP 2
Use your drilling machine, drill bit and screw with nut and mount **bracket 1** on the **north-east corner** of solar "receiver". Then mount **bracket 2** on the **bracket 1** (use enclosed screw, nut and two washers) as it's shown on the photos below (pay attention to "compass"!!!):

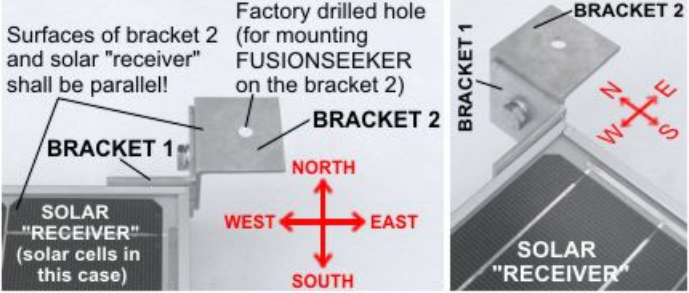

STEP 3
Mount FUSIONSEEKER on the **bracket 2**. (use screw, nut and two washers that are enclosed)

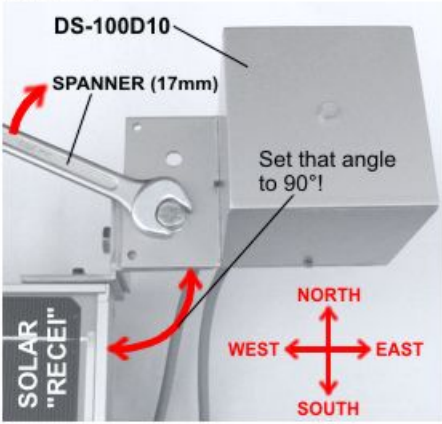

STEP 4
Set the position of DS-100D10 so that sunbeams will be falling in the right-angle onto the solar "receiver" (fine tuning). **Do this step after putting DS-100D10 in operation - during normal operation!!!**

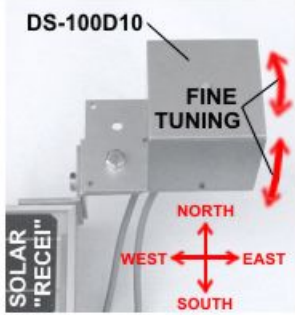

WARNING!
Bottom sensor used for early morning returning of solar "receiver" to the east **shall never be covered!** Also never cover tracking sensors!

Tighten all screws hard!

Figure 8: Mounting FUSIONSEEKER DS-100D10 on the solar "receiver" (northern hemisphere)

b) If your tracker (solar "receiver") is positioned somewhere in the southern hemisphere of the earth mount DS-100D10 on the south-east corner of your solar "receiver" as it's shown on Figure 9:

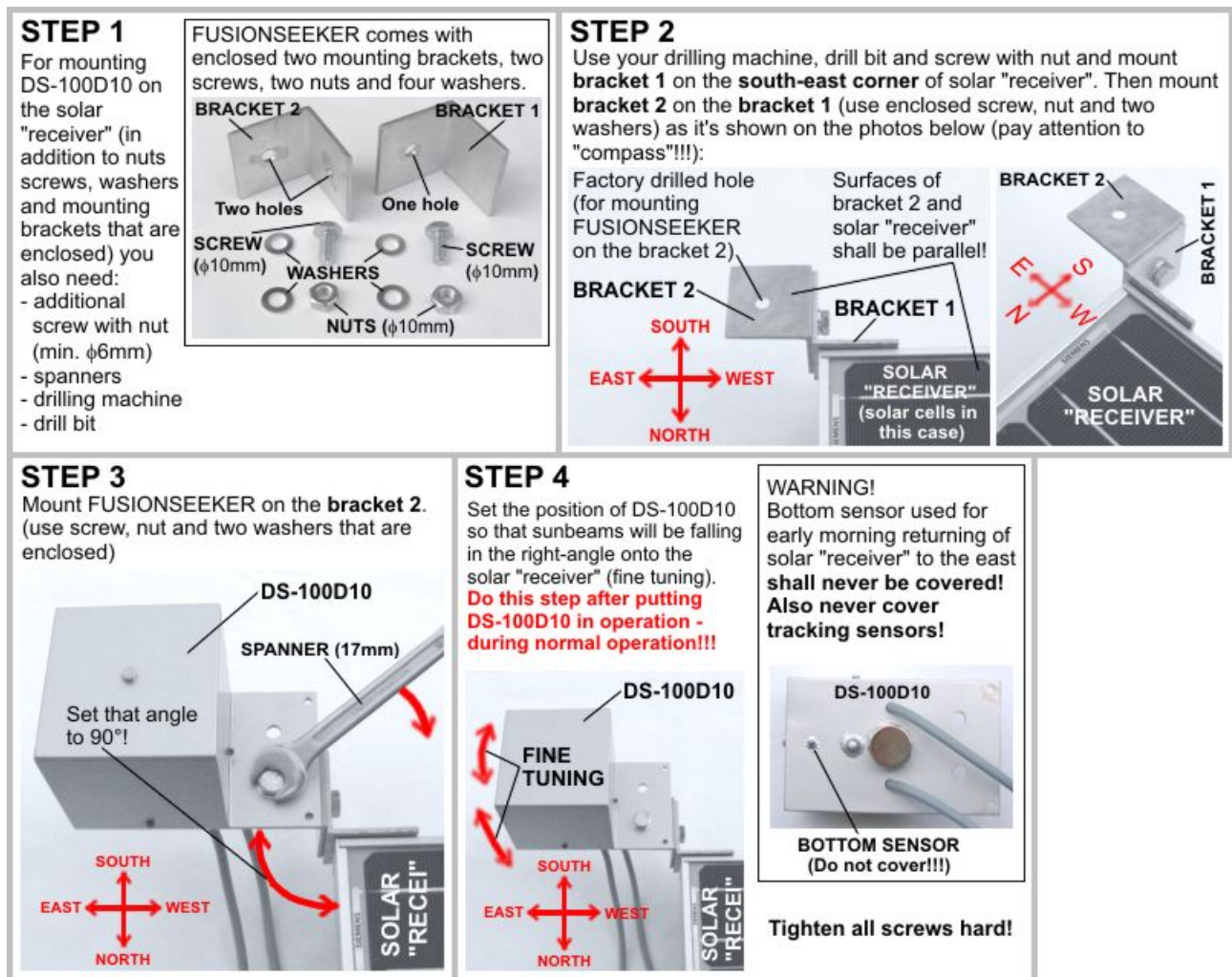

Figure 9: Mounting FUSIONSEEKER DS-100D10 on the solar "receiver" (southern hemisphere)

3.4 Connecting FUSIONSEEKER to supply voltage/s and motors

FUSIONSEEKER DS-100D10 has two 4-wire connection cables. Two wires of connection cable which is used for azimuth tracking (it's marked with the flag "AZIMUTH") are used to connect it to "azimuth" supply voltage and the other two wires of that cable are used to connect it to "azimuth" permanent magnet DC motor. Two wires of the other connection cable which is used for elevation tracking (it's marked with the flag "ELEVATION") are used to connect it to "elevation" supply voltage and the other two wires of that cable are used to connect it to "elevation" permanent magnet DC motor.

Before you start you have to check two conditions:

If continuous "azimuth" motor current ($I_{out,cont.}$) or/and continuous "elevation" motor current ($I_{out,cont.}$) is equal or lower than 10A (when motor is fully loaded) the first condition for connecting the motors to DS-100D10 is satisfied.

The second condition depends on the "type of supply voltage" you are going to use for powering "azimuth" and "elevation" part of DS-100D10 (the following points a) and b) describe the second condition in general but it applies separately to both "azimuth" and "elevation" part of DS-100D10):

a) Powering FUSIONSEEKER DS-100D10 from a battery bank or external power supply:

In this case you have to be careful that FUSIONSEEKER's maximum allowed motor current ($I_{out,max} = 45A$) is not exceeded during motor startup. This maximum motor current ($I_{motor,max}$) depends on supply voltage (U_{in}) you are going to use and on resistance of motor's coil (R_m) (you can measure it with ohm-meter when motor is not running!). When you have both values you calculate your maximum motor current ($I_{motor,max}$) with the help of the following formula: $I_{motor,max} = U_{in} / R_m$

If maximum motor current ($I_{motor,max}$) does not exceed 45A and if continuous motor current ($I_{out,cont.}$) does not exceed 10A (first condition) you can connect your motor!

Here are some examples of calculating $I_{motor,max}$:

Example 1: $I_{motor,max} = U_{in} / R_m = 12V / 0,4\Omega = 30A \rightarrow$ you can connect your motor

Example 2: $I_{motor,max} = U_{in} / R_m = 100V / 2,3\Omega = 43,5A \rightarrow$ you can connect your motor

Example 3: $I_{motor,max} = U_{in} / R_m = 48V / 0,8\Omega = 60A \rightarrow$ you can not connect your motor

b) Powering FUSIONSEEKER DS-100D10 directly from solar cells (solar panels):

In this case limitation depends on the input voltage range (A, B or C) you are going to use and on the **minimum allowed resistance of motor's coil (R_m)** as follows:

- If DS-100D10 is set to voltage range A the motor's coil resistance has to be higher (or equal) than $1,2\Omega$
- If DS-100D10 is set to voltage range B the motor's coil resistance has to be higher (or equal) than 8Ω
- If DS-100D10 is set to voltage range C the motor's coil resistance has to be higher (or equal) than 30Ω

If those conditions are satisfied and if continuous motor current ($I_{out,cont.}$) does not exceed 10A (first condition) you can connect your motor!

WARNING! When powering FUSIONSEEKER DS-100D10 directly from solar panels you have to be aware that maximum output voltage of 12V solar panel is around 22V, of 24V solar panel around 44V, of 48V solar panel around 88V, etc. For example, you can not power FUSIONSEEKER DS-100D10 from 24V solar panel when it's set to voltage range A (max. $U_{in} = 25V$) because maximum input voltage of voltage range A is 25V and maximum possible output voltage of 24V solar panel is 44V!!! **Remember, you can power DS-100D10 only from 12V solar panels (set it to voltage range A!!!), from 24V solar panels (set it to voltage range B!!!) and from 48V solar panels (set it to voltage range C!!!). That warning applies separately to both "azimuth" and "elevation" part of DS-100D10!**

WARNING! If you have tracking system with solar panels and batteries and you use PWM charge controller to charge those batteries you have to power DS-100D10 directly from batteries.

Explanation: When batteries are full PWM charge controller makes short circuit on solar panel's output to prevent overcharging. That means output voltage from panel is 0V and DS-100S10 like any other electrical device can not work without power. **That warning applies separately to both "azimuth" and "elevation" part of DS-100D10!**

The next step is calculating the minimal size (cross-sectional area in mm²) of wires for cables (copper wires!!!) you will use to connect DS-100D10 to supply voltage/s and motors (connection cables of DS-100D10 are short!).

The minimal size for 1 wire of 2-wire "azimuth" motor cable you will use depends on **the length of that 2-wire "azimuth" motor cable** and on **actual continuous "azimuth" motor current**. You calculate it using the following formula:

Minimal size for 1 wire of cable[mm²]={(0,036)x(cable length[m]) x (cont. motor current[A])}+0,8

Example: cable length = 12m; actual continuous "azimuth" motor current = 10A;
Minimal size for 1 wire of cable[mm²] = {(0,036) x (12) x (10)} + 0,8 = 5,12mm²
Use first higher standard size; in this case use 2-wire cable with one wire size of 6mm² (shortly: 2 x 6mm² cable)

The minimal size for 1 wire of 2-wire "elevation" motor cable you will use calculates using the same formula (just consider **actual continuous "elevation" motor current and the length of that 2-wire "elevation" motor cable**).

To calculate the minimal size for 1 wire of 2-wire "azimuth" and "elevation" power supply cables also use the same formula. Current values (cont. "azimuth" and "elevation" motor current) stay the same just take into account **"azimuth" and "elevation" power supply cable length**.

Finally, if you satisfy **all** conditions and you have cables you can now physically connect FUSIONSEEKER DS-100D10.

All 4 wires of "azimuth" connection cable are marked (number or colour):

- To wire marked with "1" connect **positive power supply wire (+U)**
- To wire marked with "2" connect **negative power supply wire (-U)**
- To wire marked with "3" connect **one "azimuth" motor wire**
- To wire marked with "yellow/green" colour connect **the other "azimuth" motor wire.**

All 4 wires of "elevation" connection cable are also marked (number or colour):

- To wire marked with "1" connect **positive power supply wire (+U)**
- To wire marked with "2" connect **negative power supply wire (-U)**
- To wire marked with "3" connect **one "elevation" motor wire**
- To wire marked with "yellow/green" colour connect **the other "elevation" motor wire.**

Power supply for azimuth and elevation tracking can be common (one) or you can use two – one for azimuth tracking and the other for elevation tracking – see **Section 3.1!**

We recommend you to use the procedure shown on **Figure 10** to "join" "azimuth" and "elevation" connection cables with "azimuth" and "elevation" power supply cables and "azimuth" and "elevation" motor cables.

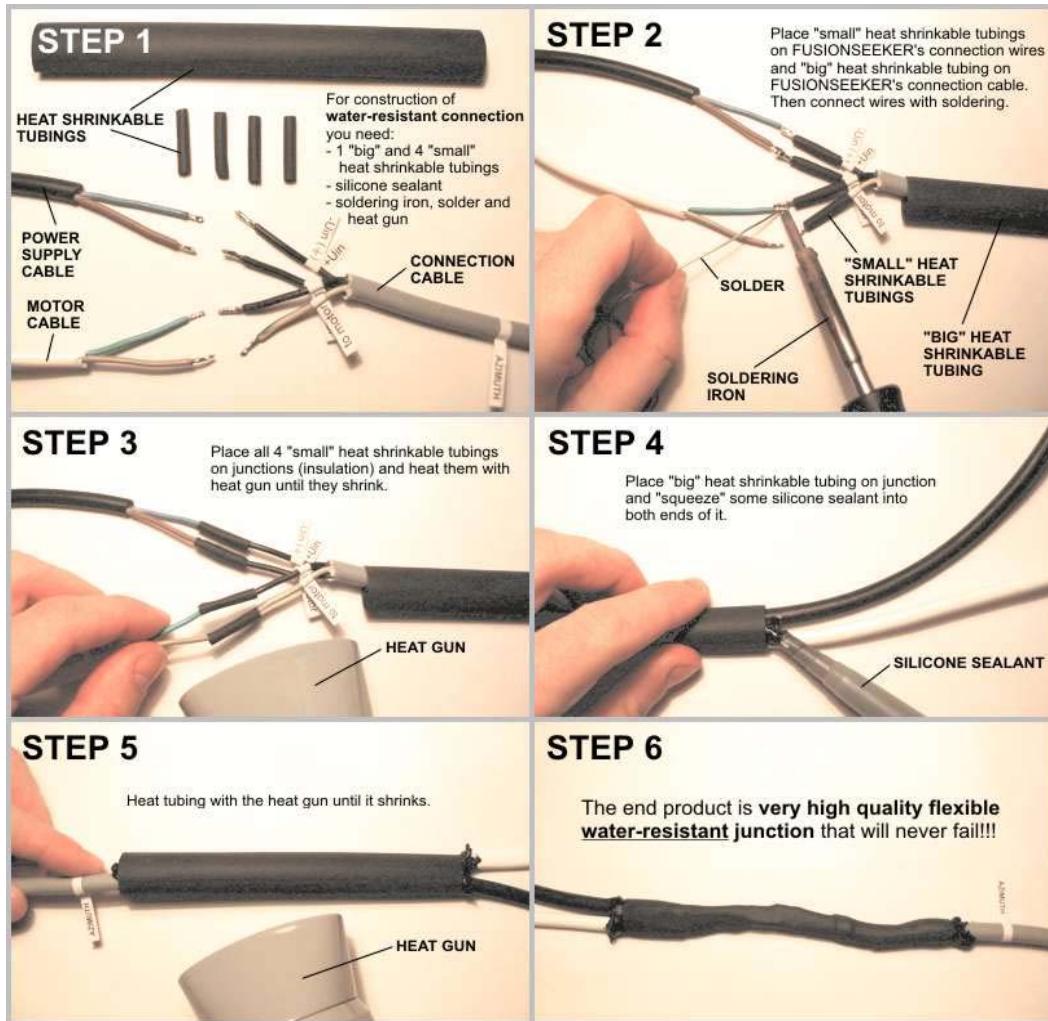

Figure 10: "Joining" "azimuth" or "elevation" connection cable with its power supply cable and motor cable

For azimuth tracking **first** connect "azimuth" motor cable to "azimuth" motor and **after that** connect "azimuth" power supply cable to your power source (supply voltage) – of course you have to set suitable "azimuth" voltage range before!!! **And don't forget, the positive "azimuth" power supply wire must be fused near power source with 10A DC-rated fast fuse.** If the "azimuth" motor is less powerful you can use lower-rated fuse.

For elevation tracking **first** connect "elevation" motor cable to "elevation" motor and **after that** connect "elevation" power supply cable to your power source (supply voltage) – of course you have to set suitable "elevation" voltage range before!!! **And don't forget, the positive "elevation" power supply wire must be fused near power source with 10A DC-rated fast fuse.** If the "elevation" motor is less powerful you can use lower-rated fuse.

When you finish FUSIONSEEKER DS-100D10 starts working. If you don't have luck your tracker will be turning in the opposite direction (by "azimuth" or/and "elevation"). Don't worry, just disconnect DS-100D10 from power source, substitute motor wires in the wrong working motor's junction-box, connect power supply back and the system will now work properly. We would tell you how to properly connect motors in the first "attempt" but it's impossible due to very large number of different actuators on the market.

WARNING! Be careful, always connect FUSIONSEEKER's number "1" wire to positive terminal of power source and number "2" wire to negative terminal of power source!!! You will damage DS-100D10 if you make a mistake.

We also recommend you to fasten all cables on the tracker in the way they won't be able to move freely where they are not supposed to. While doing that you should also take care of both connection cables in the location where they come out from the housing (see **Figure 11**).

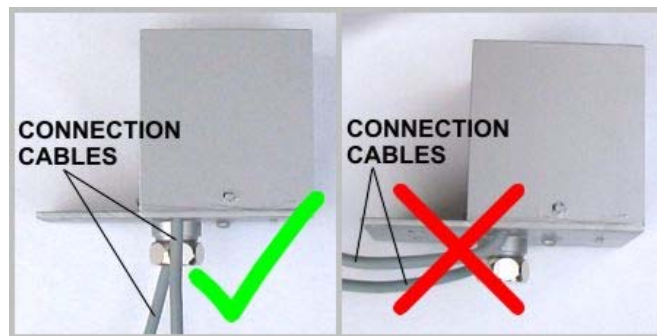

Figure 11: Allowed and not allowed treatment of connection cables

3.5 The use of limit switches

Limit switches are always important part of each tracker because they protect actuators (motors) by stopping them slightly before physical rotational limits of the tracker are reached. Rotational limits could be reached in case something goes wrong or when the tracker mechanics is normally not capable of rotating for example more than ± 70 degrees in either direction. Although FUSIONSEEKER DS-100D10 was designed to work even without limit switches (in case tracker's rotational limits are normally never reached) we recommend you to use it. So, install limit switches as it's shown on **Figure 12**.

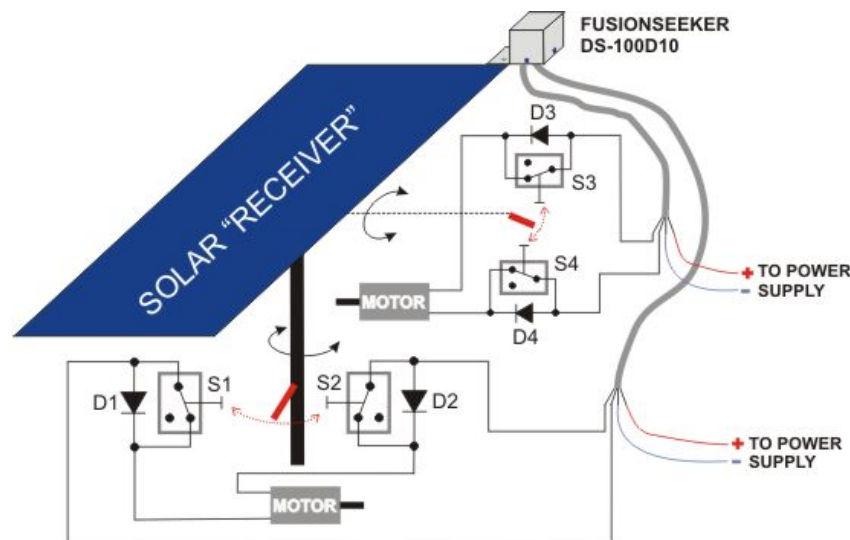

Figure 12: Installing the limit switches

During installation of limit switches S1, S2 and S3, S4 you have to be careful to set them in the way they will turn off azimuth and elevation actuator motor slightly before rotational limits of the tracker are reached. Also be careful to use enough powerful limit switches (S1, S2 and S3, S4) and diodes (D1, D2 and D3, D4).

If you don't have luck limit switches, although properly activated, won't turn off azimuth or/and elevation motor. In this case immediately disconnect DS-100D10 from the power source (or two power sources). If azimuth motor is not turned off substitute leads of diode D1 and substitute leads of diode D2. In case elevation motor is not turned off substitute leads of

diode D3 and substitute leads of diode D4. Then connect power supply back and limit switches will work properly.

3.6 Grounding

The housing of FUSIONSEEKER DS-100D10 is made of pure aluminium what means that **it must be grounded**. Its housing already has two holes where you connect ground wire - the other side of ground wire **must be connected to system ground**. For details see **Figure 14**.

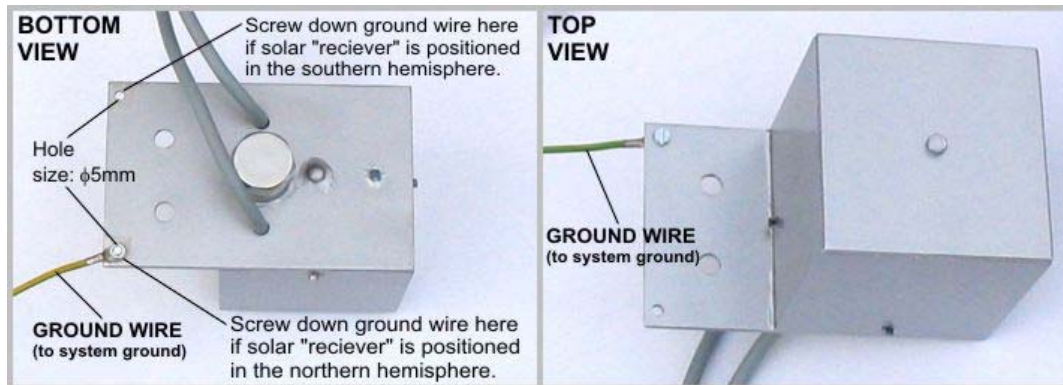

Figure 14: Grounding the FUSIONSEEKER DS-100D10

WARNING! Never ground motor wires! Motor wires must be connected to motor terminals and nowhere else otherwise short circuit will occur and your DS-100D10 will possibly be permanently damaged.

4. RECOMMENDATIONS FOR SOLAR TRACKER STRUCTURE

- **The solar tracker structure including actuators shall be so strong that it can withstand even strongest winds!**
- **The solar tracker structure shall be as stiff as reasonably achievable!** Explanation: Stiff structure assures that tracker can not sway in the wind – left, right, left, right, left,... FUSIONSEEKER DS-100D10 can detect this swaying as deviation in sun tracking and it every time turns on azimuth or/and elevation motor in one and the other direction what means that tracker **oscillates**. Oscillations can harm azimuth or/and elevation actuator motor or even DS-100D10 (in case of large startup currents). Take into account that stiffness of the tracker structure has to be higher if higher accuracy is set.
- **Actuators (or gear drives) has to be high quality – without clearance!** Explanation: Actuator's clearance can cause oscillations in windy conditions in the same way as low stiffness.
- **The azimuth and also elevation speed of rotation of the solar tracker shall not be faster than 36° per minute (5 minutes for 180° turn) in general. For accuracies better than ±0,05 degree the recommended speed of rotation is slower than 18° per minute (10 minutes for 180° turn).** Explanation: The motors can not stop in zero seconds and they rotate a little bit further (because of persistence). DS-100D10 can detect this as deviation in sun tracking and it turns on the motor/s in the other direction to "repair" the error. If this is repeating oscillations are here. But if recommended tracker's speed of rotation is considered this type of oscillation can not occur because DS-100D10 has built in electronic motor brake which stops the motors immediately after they are turned off (almost in zero seconds!)
- **Mount solar tracker in the place where nearby objects can never shadow it!**

5. WARRANTY

Fusionseeker Solar Tracker Controllers (*a division of Sončna energija d.o.o., Kidriceva ulica 25, 3000 Celje, SLOVENIA (E.U.)*) warrants its product to the original consumer purchaser that it will repair, or replace, any product that is determined to be defective for the following terms:

One year from date of purchase on all components.

To be eligible for repair or replacement under this warranty, the product in question must be sent to Fusionseeker Solar Tracker Controllers (to workshop – address is shown below) within the warranty period and the original consumer purchaser must comply with the following conditions:

- The product thereof must not have been modified or altered in any way by an unauthorized source.
- The product thereof must have been installed in accordance with the installation instructions.

This limited warranty does not cover:

- Damage due to improper or installation;
- Accidental or intentional damage;
- Misuse, abuse, corrosion, or neglect;
- Product impaired by severe conditions, such as excessive wind, ice, storms, lightning strikes or other natural occurrences;
- Damage due to improper packaging on return shipment.

Any and all labor charges for troubleshooting, removal or replacement of the product are not covered by this warranty and will not be honored by Fusionseeker Solar Tracker Controllers.

Return shipping is to be pre-paid by the original consumer purchaser. Fusionseeker Solar Tracker Controllers will pay the normal return shipping charges within the European Union countries only.

THIS WARRANTY IS EXPRESSLY IN LIEU OF ALL OTHER WARRANTIES OF ANY KIND, EXPRESSED OR IMPLIED, INCLUDING (WITHOUT LIMITATION) ANY IMPLIED WARRANTIES OF MERCHANTABILITY OR FITNESS FOR A PARTICULAR PURPOSE, AND OF ANY NONCONTRACTUAL LIABILITIES BASED UPON NEGLIGENCE OR STRICT LIABILITY. IN NO EVENT SHALL FUSIONSEEKER SOLAR TRACKER CONTROLLERS BE LIABLE FOR INCIDENTAL OR CONSEQUENTIAL DAMAGES, INCLUDING (WITHOUT LIMITATIONS) ANY DAMAGE FOR PERSONAL INJURY OR PROPERTY DAMAGE OR OTHER PRODUCT LIABILITIES BASED UPON ALLEGED NEGLIGENCE OR BREACH OF EXPRESS OR IMPLIED WARRANTIES OR STRICT LIABILITY. FUSIONSEEKER SOLAR TRACKER CONTROLLERS NEITHER ASSUMES NOR AUTHORIZES ANY OTHER PERSON TO ASSUME FOR IT ANY OTHER OBLIGATION IN CONNECTION WITH THE SALE OF ITS PRODUCTS. THIS WARRANTY GIVES YOU SPECIFIC LEGAL RIGHTS, AND YOU ALSO MAY HAVE OTHER RIGHTS THAT MAY VARY FROM COUNTRY TO COUNTRY. SOME COUNTRIES DO NOT ALLOW LIMITATIONS ON HOW LONG AN IMPLIED WARRANTY WILL LAST OR THE EXCLUSION OR LIMITATION OF INCIDENTAL OR CONSEQUENTIAL DAMAGES, SO THE ABOVE LIMITATIONS OR EXCLUSIONS MAY NOT APPLY TO YOU.

Address of Fusionseeker Solar Tracker Controllers workshop:

Dejan Skrivalnik
Pisece 20
8255 Pisece
SLOVENIA (E.U.)
Phone: 00-386-41-937-343
E-mail: fusionseeker@gmail.com